

MODEL 247C
PORTABLE DIFFERENTIAL PRESSURE INDICATOR
(For use with 224C DPU)

Installation Manual
Part No. 10150, Rev. 01
July 2007

[This manual is for indicator only - see separate 224/224C DPU manual.]

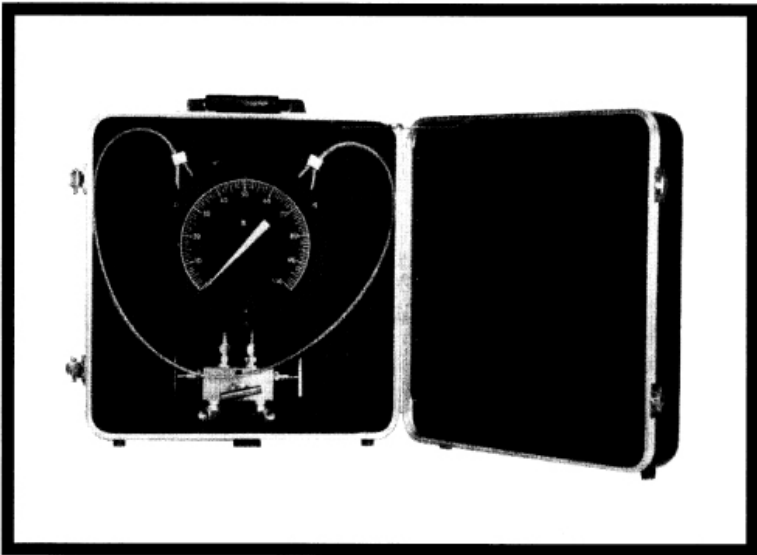

PRODUCT WARRANTY STATEMENT

The product warranty applicable to this Barton instrument is as stated on the inside back cover of this manual.

SAFETY

Before installing the instrument, become familiar with the installation instructions presented in Section 3.



DANGER notes indicate the presence of a hazard which **will** cause **severe** personal injury, death, or substantial property damage if the warning is ignored.



WARNING notes indicate the presence of a hazard which **can** cause **severe** personal injury, death, or substantial property damage if the warning is ignored.



CAUTION notes indicate the presence of a hazard which **will** or **can** cause moderate personal injury or property damage if the warning is ignored.

DANGER, WARNING and/or **CAUTION** notes that appear on the following page of this manual should be reviewed before proceeding: **5-1**.

RECORD OF CHANGES

CHANGE NO.	DATE	DESCRIPTION	ENTERED BY
79K5	3/14/80	Assigned new manual number; revised text and illustrations; set to new format.	J. Herrick
83A3	11/82	Revised text. Deleted information pertaining to Models 226 & 246 DP Indicators.	P. Shepherd
84H3	8/84	Deleted information pertaining to Model 227. Added 'A' model mechanism information.	S. Mackey
94B7	3/94	Revised Section 5 to match 227 I/O manual.	R. Ramos
95J2	10/95	Cover & Page 1-2: New photos. Page 3-1, Sec. 3-3.A: Replaced "hook inside case" with "cable attached to indicator". Page 6-4 & 6-5: Revised Parts Identification & Parts List. Page 7-2: Added updated 247A drawing. Replaced 224 Appendix with new 224C Appendix.	S. Willingham
98J3	10/98	Revised company name/logo throughout manual. Changed model references to "C" version.	S. Gold
01	7/07	Revised corporate name/logo/contact information to reflect Cameron ownership.	K. Metzger

TABLE OF CONTENTS

SECTION	TITLE	PAGE
1	INTRODUCTION	
1-1	GENERAL	1-1
1-2	PRODUCT DESCRIPTION	1-1
1-3	SPECIFICATIONS	1-3
2	THEORY OF OPERATION	
2-1	GENERAL	2-1
2-2	DIFFERENTIAL PRESSURE UNIT	2-1
2-3	INDICATOR	2-1
3	INSTALLATION	
3-1	UNPACKING	3-1
3-2	DPU INSTALLATION	3-1
3-3	MOUNTING	3-1
4	OPERATION	
4-1	STARTUP	4-1
5	MAINTENANCE AND CALIBRATION	
5-1	DPU INSPECTION AND CLEANING	5-1
5-2	TOOLS REQUIRED FOR MAINTENANCE	5-1
5-3	RANGE CHANGES	5-1
5-4	BELLOWS UNIT ASSEMBLY	5-1
5-5	CALIBRATION CHECK	5-3
5-6	COMPLETE CALIBRATION	5-4
5-7	TROUBLESHOOTING	5-5
6	PARTS LIST	
6-1.	GENERAL	6-1
7	PARTS DRAWING	
7-1.	OUTLINE DIMENSION DRAWINGS	7-1
APPENDIX	— Installation and Operation Manual, Model 224C Differential Pressure Unit	

LIST OF ILLUSTRATIONS

FIGURE	TITLE	PAGE
1-1	Model 247C Portable Differential Pressure Indicator	1-2
2-1	Differential Pressure Indicator	2-2
5-1	Linkage Assembly at 50% Differential Pressure	5-3
6-1	Model 247C Parts Identification	6-2
6-2	Model 247C Differential Indicator Assembly Parts Identification	6-4

LIST OF TABLES

TABLE	TITLE	PAGE
1-1	Differential Pressure Indicator Specifications	1-3
5-1	Troubleshooting Chart	5-5
6-1	Parts List, Model 247C Differential Pressure Indicator	6-3
6-2	Parts List, Model 247C Indicator Assembly	6-5

SECTION 1

INTRODUCTION

1-1. GENERAL

The Barton Model 247C Differential Pressure Indicator (Figure 1-1) is a portable indicator used to measure liquid flow or liquid level. Except for additional manifold valves and piping it is identical with the Model 227C indicator, which is designed for permanent installation.

For flow measurements, the instrument is connected to the low- and high-pressure sides of a primary device located in the process run. The primary device may be any pressure drop device such as an orifice plate, venturi tube, or flow tube.

For liquid level measurements, the instrument is connected to monitor changes in hydrostatic pressure caused by variations of liquid height in a vessel.

1-2. PRODUCT DESCRIPTION

The Model 247C Differential Pressure (D.P.) Indicator is actuated by an Barton Model 224C Differential Pressure Unit (DPU).

The indicating pointer traverses a 270° arc to measure differential pressure which implies flow or liquid level. The Model 247C has a 6" dial with an extended dial scale of 13-1/2" for ease of reading.

The movement of the D.P. Indicator has a micrometer screw for span adjustment. This adjustment may be performed without removing the scale plate or the indicating pointer. The zero point is adjusted by moving the pointer and likewise, does not necessitate removal of the scaleplate.

The D.P. Indicator Model 247C is a portable unit, designed for intermittent measurements of flow rates of differential pressure. The model is provided with three-valve manifolds as an integral part of its design. The manifold is a unitized block construction having two block valves and a bypass valve. Valves are also provided at the DPU for bleeding or venting. The Model 247C is a case-mounted instrument, and the case is provided with a hook for vertical positioning of the instrument.

The Model 224C DPU is described in the Appendix.

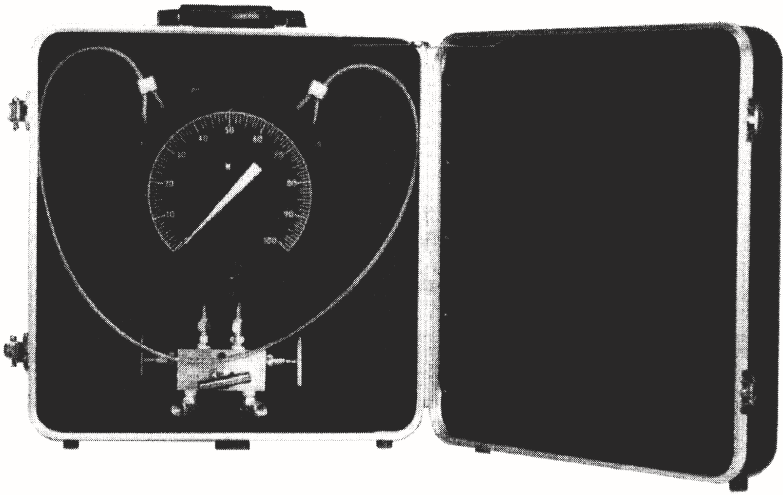

Figure 1-1. Model 247C Portable Differential Pressure Indicator

1-3. SPECIFICATIONS

A. General Specifications

General specifications for the D.P. Indicators are presented in Table 1-1.

Table 1-1. Differential Pressure Indicator General Specifications

		Available Differential Pressure Ranges			
		Stainless Steel Bellows		Beryllium Copper Bellows	
SWP-psi	Housing Material	1-5/8 O.D.	3/4" O.D.*	1-5/8" O.D.	3/4" O.D.
500	Forged Brass (ASTM-B124 #2)			0-30" w.c. to 0-24.5 psi	0-25 psi to 0-400 psi
500	Stainless Steel (316)	0-30" w.c. to 0-55 psi	0-60 psi to 0-500 psi	0-30" w.c. to 0-24.5 psi	0-25 psi to 0-500 psi
Net Volume in cu. in.	L.P. Head	1.66	2.51	1.66	2.51
	H.P. Head	1.55	2.42	1.55	2.42
Displacement in cu. in.		.14	.03	.14	.03

B. Performance Specifications

Accuracy:

Ranges up to 200 psi $\pm 1/2\%$ of full scale differential pressure

Ranges above 200 psi $\pm 3/4\%$ of full scale differential pressure

Temperature Limitations -40°F to +180°F

NOTE

Zero center or split ranges are available on special order. For example, a 0-50" w.c. range may be ordered 25-0-25" w.c. or 10-0-40" w.c.

SECTION 2

THEORY OF OPERATION

2-1. GENERAL

The bellows within the DPU move in response to changes in the differential pressure measured at the primary device installed in the process system. Movement of the bellows is mechanically transferred to the indicator mechanism which in turn positions the indicating pointer.

2-2. DIFFERENTIAL PRESSURE UNIT

A detailed description of DPU operation is presented in the Appendix.

Changes in pressure within the Differential Pressure Unit pressure housings cause the DPU bellows to move in the direction of the decreasing pressure.

Movement of the bellows is transferred to the DPU torque tube output shaft. The torque tube shaft is the mechanical output of the DPU which is attached to the back of the indicator case. The torque tube shaft is connected to the indicator mechanism.

2-3. INDICATOR (See Figure 2-1)

The DPU torque tube shaft is connected to the drive arm of the indicator mechanism. The torque tube shaft rotates in response to DPU bellows movement and this rotation is mechanically transmitted through the drive arm and associated mechanism to position the pointer on the scale to the indication relative to the differential pressure measured by the DPU.

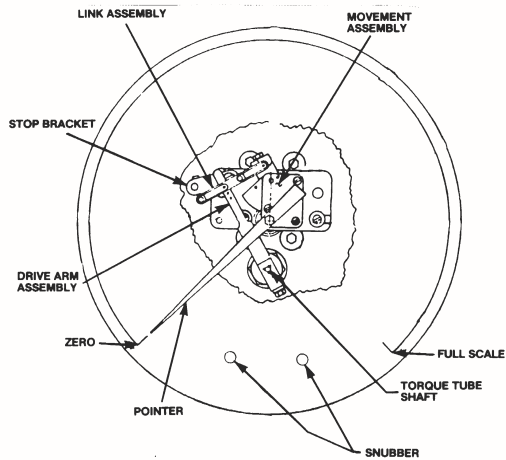

Figure 2-1. Differential Pressure Indicator

2-1/2-2 (Blank)

SECTION 3

INSTALLATION

3-1. UNPACKING

All Barton instruments are tested and inspected during manufacture and prior to shipment. However, an inspection should be performed at the time of unpacking to detect any damage that may have occurred during shipment.

For applications in critical media, requiring special cleaning processes and precautions, a polyethylene bag is used to protect the instrument from contamination. This protective bag should be removed only under conditions of extreme cleanliness.

The following items are included in each container:

- Model 247C Differential Pressure Indicator
- Installation and Operation Manual
- Accessories per customer order.

3-2. DPU INSTALLATION

See the Appendix for DPU installation and piping instructions.

3-3. MOUNTING (Refer to the applicable outline drawing presented in Section 7.)

NOTE

The instrument must be mounted in an approximately level position for proper operation.

A. Mounting (Model 247C)

The case of the Model 247C D.P. Indicator is provided with a cable attached to the indicator, for hanging the instrument in a vertical position.

SECTION 4

OPERATION

4-1. STARTUP

Instructions pertaining to DPU startup and operation procedures are presented in the Appendix.

4-1/4-2 (Blank)

SECTION 5

MAINTENANCE AND CALIBRATION

5-1. DPU INSPECTION AND CLEANING

Instructions pertaining to DPU inspection and cleaning are presented in the Appendix.

5-2. TOOLS REQUIRED FOR MAINTENANCE

Tools required for removing DPU pressure housing bolts and maintenance of the DPU are listed in the Appendix.

The following tool list is applicable to the indicator:

Equipment	Purpose
Pointer puller	Pointer removal
Small screwdriver	Calibration adjustments
Medium screwdriver	Bezel removal
1/8" Open-end wrench	Calibration adjustments
50 lb. Torque wrench	Pressure housing bolts
3/16" Allen socket wrench	Pressure housing bolts
5/16" Allen socket wrench	Pressure housing bolts
Calibration Kit (Item 20, Table 6-1)	

5-3. RANGE CHANGES

To change the range of the Model 224C DPU, it is necessary to replace the BUA with a unit of the desired range. Replacement assemblies, range descriptions, and general instructions are presented in the Appendix.

5-4. BELLOWS UNIT ASSEMBLY

CAUTION

DO NOT LOOSEN THE TWO PLUGS LOCATED ON THE BUA CENTER PLATE WHEN REMOVING THE MOUNTING BRACKET. TO DO SO WILL CAUSE LOSS OF BELLOWS FILL FLUID AND RENDER THE UNIT INOPERABLE.

A. Lens and Scale Plate Removal of Model 247C (Refer to Figure 6-1 to identify the parenthetical numbers used in the following text.)

Before changing the BUA or calibrating the instrument, remove the lens, scale plate, and pointer of the indicator as described below:

1. Loosen three bezel screws located on the front of the bezel.
2. Tilt out the bottom of the bezel and slide the bezel upward.
3. Remove the indicating pointer using the pointer puller.
4. Remove the scale mounting screws and remove the scale plate.

Disassembly to this point provides full access to all indicator movement parts and adjustments.

B. Bellows Unit Replacement

To replace the DPU BUA, proceed as follows.

1. Remove the instrument from service.
2. Remove the bezel, cover glass, pointer, scale plate of the indicator.
3. Loosen and remove the drive arm.
4. Remove the indicator movement mounting screws.
5. Remove the four Allen head DPU mounting screws, and separate the DPU from the indicator case.

NOTICE

Do not loosen the two plugs located on the BUA center plate when removing the mounting bracket. If either plug is loosened, the bellows fill fluid will be lost and the DPU will require factory refill.

6. Remove the DPU mounting bracket, pressure housing screws and the pressure housings.

NOTICE

Incorrect bezel gasket orientation will cause the instrument's indicator to jam, resulting in inaccurate readings. Ensure correct bezel gasket orientation before placing the instrument in service, as shown below.

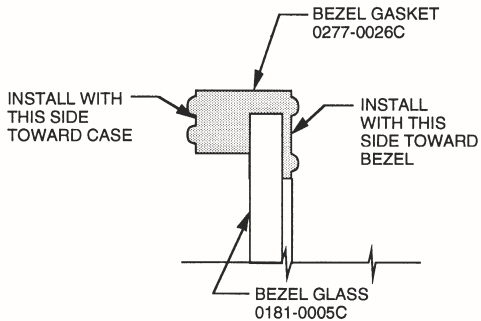

The bezel gasket (0277.0026C) must be orientated as shown above. The two snubbers (0266.0028C) on the scale plate should not be compressed against the glass cover. The pointer should not be touching the glass cover.

7. Reassemble the DPU using the replacement BUA and following steps 2 through 6 in reverse order.
8. Calibrate the instrument in accordance with #5 and #6.

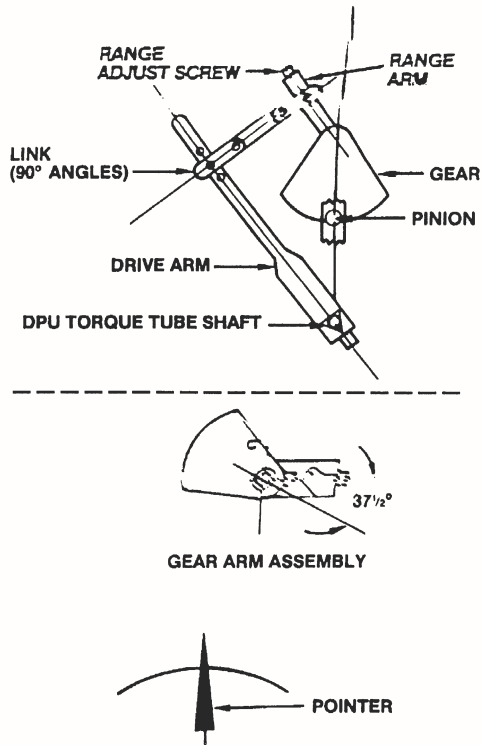

Figure 5-1. Linkage Assembly at 50% Differential Pressure

5-5. CALIBRATION CHECK

Normally all that is required to adjust the indicator to the factory-set calibration tolerances is to perform the following calibration check.

1. Connect the instrument to a standard pressure source as shown in the Appendix.
2. Remove the plug from the low pressure housing.
3. Apply approximately 150% of the differential pressure range to the high pressure housings. Release pressure. Repeat 3 or 4 times.
4. Apply 0%, 50% and 100% of full scale pressure (see Figure 5-1). If indication is within the specified limits, no further adjustments are necessary. If the zero indication is incorrect, remove the bezel and glass assembly, and adjust the pointer by turning the pointer by the hub.
5. Replace the bezel and glass assembly.

5-6 COMPLETE CALIBRATION

A complete calibration of the instrument is required whenever the DPU assembly is replaced. Refer to Figures 2-1 and 5-1, and the Appendix while performing the calibration procedure.

1. Connect the instrument to a standard pressure source as shown in the Instrument Calibration Setup illustration in the Appendix.
2. Attach linkage between drive arm and movement. (The following illustration shows alignment at 50% differential pressure.)

Inspect parts for straightness and pivot-fit without binding.

3. Set the pointer at zero on the scale by slipping the pointer on the hub. Hold the pointer tip and turn the hub with a wrench.

NOTE

If replacing the pointer, it may be necessary to ream the hub to obtain the required 75% to 90% hub engagement.

4. Apply 100% differential pressure. If pointer exceeds 100% on the scale, lengthen the range arm. Remove pressure.
5. Set zero and span using the hub for the zero adjustment and the range adjust screw on the movement for span adjustments.
6. Apply 50% differential pressure. If linearity adjustment is required, loosen the drive arm and move the arm to shift the pointer in the direction of the error (approximately 10:1). Retighten drive arm.
7. Reset zero and check span. If the gear in the movement reaches its limit of travel due to the linearity adjustment, slop the gear approximately 5° from the 37.5° angle to approximately 43° . Retest at 50% and 100% differential pressure and adjust linkage until pointer readings are acceptable.
8. Apply 0%, 25%, 50%, 75%, and 100%, 75%, 50%, 25%, and 0% differential pressure to the indicator without overshoot. Lightly tap the indicator to overcome the effects of friction.
9. Test repeatability at 0%, 50%, 0% 50%.
10. Set stops to prevent pointer from striking snubbers on the scale.
11. Tighten all screws. Test by moving the pointer (by finger) from zero to 50% and return. An offset in zero reading indicates pointer slippage.

NOTE

If replacing the pointer it may be necessary to ream the hub to obtain the required 75 to 90% hub engagement.

5-7 TROUBLESHOOTING

If operating problems are encountered, refer to the Troubleshooting Chart, Table 5-1.

Table 5-1. Troubleshooting Chart

Problem	Probable Location	Possible Cause	Corrective Action
Low or No Indication	DPU	See Troubleshooting Chart in the Appendix	
	Indicator	Loose movement. Out of calibration Pointer loose. Dirt in mechanism.	Tighten or replace. Calibrate. Tighten pointer. Clean mechanism.
	Piping or Primary Source	See Troubleshooting Chart in the Appendix	
High Indication	Piping or Primary Source	See Troubleshooting Chart in the Appendix	
	DPU	See Troubleshooting Chart in the Appendix	
	Indicator	Loose arms or mechanism. Out of calibration	Tighten Mechanism Calibrate
Erratic Indication	Primary Element	See Troubleshooting Chart in the Appendix	
	Piping	See Troubleshooting Chart in the Appendix	
	DPU	See Troubleshooting Chart in the Appendix	
	Indicator	Movement dragging or dirty. Pointer dragging on scale plate.	Adjust or clean movement. Adjust pointer position.

SECTION 6
PARTS LISTS

6-1. GENERAL

The parts list and parts identification for the Model 224C Differential Pressure Unit are presented in the Appendix.

The component parts for the Model 247C are identified in Figure 6-1 and listed in Table 6-1.

The component parts for the Model 247C Indicator Assembly are identified in Figure 6-2 and listed in Table 6-2.

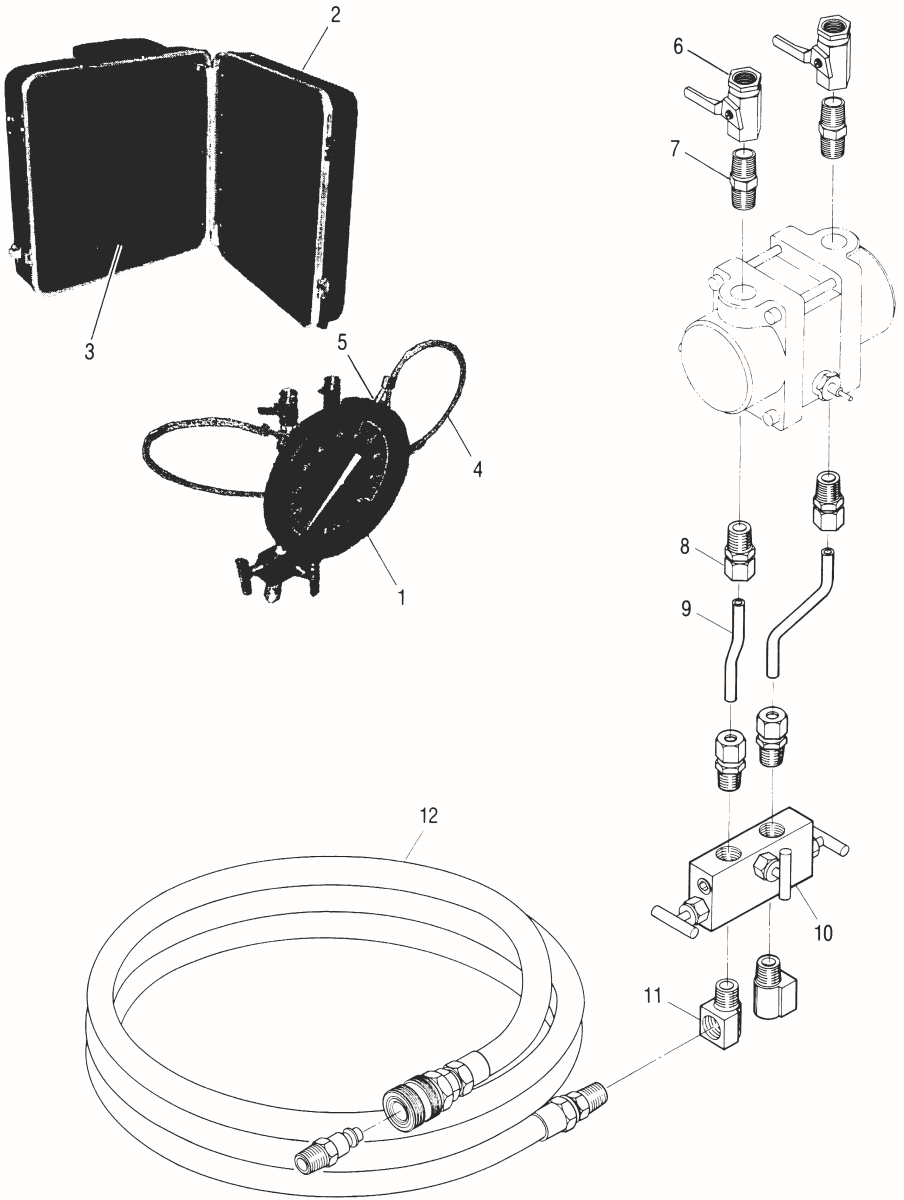

Figure 6-1. Model 247C Parts Identification

Table 6-1. Parts List, Model 247C Differential Pressure Indicator

Item	Description	Part No.	Per Unit
For the Model 224C Differential Pressure Unit (Not Shown), See the Appendix			
1	Indicator Assembly (Refer to Table 6-2 and Figure 6-2 for parts breakdown)	—	1
2	Carrying Case	0039.1125.T	1
3	Foam Insert	0021.1001.T	1
4	*Cable	0027.1088.T	1
5	*Lug	0169.1028.T	2
	(*Note: Cable Assembly, consisting of Items 4 & 5)	0247.1002.B	1
6	Valve, Ball:		2
	Brass	0001.1001.Q	
	Stainless Steel	0001.0009.Q	
7	Bushing, Pipe:		2
	Brass	0902.0002.L	
	Stainless Steel	0902.0001.L	
8	Connector, Tube:		4
	Brass	0502.0002.M	
	Steel	0504.0001.M	
	Stainless Steel	0505.0008.M	
9	Tubing, Manifold:		4
	Brass	0235.0001.C	
	Steel	0235.1001.C	
10	Manifold:		1
	Brass	0001.0014.Q	
	Steel	0001.0015.Q	
	Stainless Steel	0001.0016Q	
11	Elbow	0102.0008.L	2
12	Assembly, Neoprene Hose	0074.0002.T	2
13	Nameplate, Instruction (Not Shown on drawing)	0226.0001.G	1

NOTE:

When ordering parts, please specify serial number of the instrument with which they are to be used.

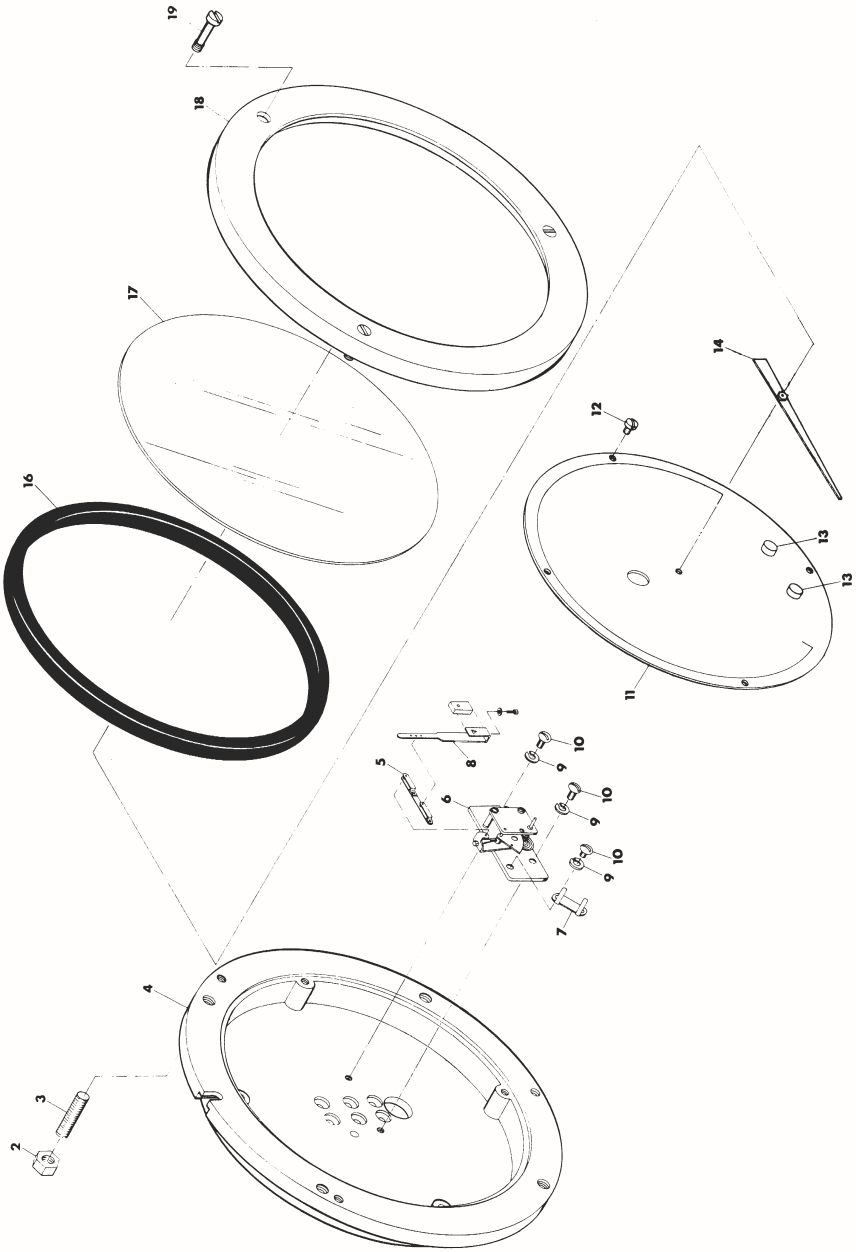

Figure 6-2. Model 247C Indicator Assembly Parts Identification

Table 6-1. Parts List, Model 247C Indicator Assembly

Item	Description	Part No.	Per Unit
1	Differential Pressure Unit (Not Illustrated)	(See Appendix)	1
2	Nut	0500.0001.J	4
3	Screw, Slotted Set, 1/4-20 x 1", St. C.P.	0340.0003.J	4
4	Case, Indicator	0227.0014.C	1
5	Assembly, Link	0226.0020.B	1
6	Assembly, Movement	0288.0035.B	1
7	Bracket, Stop	0288.0028.C	1
8	Assembly, Drive Arm	0226.0023.B	1
9*	Washer, Split Lock, #4, SS	0003.0062.K	3
10*	Screw, Binding Head, 4-40 x 3/16", SS	0117.0012.J	3
11	Scale Plate (Specify Range)	0227.1007.C	1
12*	Screw, Sl. Fil. Hd. 4-40 x 3/16", SS	0114.0023.J	4
13	Snubber	0226.0028.C	2
14*	Assembly, Pointer	0288.0031.B	1
15	Assembly, Bezel (Incl. Items 16, 17 & 18)	0277.0018.B	1
16*	Gasket	0277.0026.C	1
17*	Cover	0181.0038.C	1
18	Bezel	0277.0029.C	1
19*	Screw, Bezel	0181.0007.C	3
20*	Kit, Calibration (Not Shown, includes Pointer Puller)	0288.1032.B	1

*Indicates recommended spare parts.

When ordering parts, include instrument serial number.

NOTES:

* Indicates recommended spare parts.

1. When ordering parts, please specify serial number of instrument with which they are to be used.

2. Scale Plate Identification:

If the scale plate shows an "SCR" number, this will identify it. Otherwise, give the following information:

- (a) Square root or linear graduation.
- (b) Scale, e.g., 0-100, 24-0-100, etc.
- (c) Number of graduations (linear scales only).
- (d) Data, e.g., "PSI," "Inches of Water Column," etc.
- (e) Standard plates have black background.

SECTION 7

DRAWINGS

7-1. OUTLINE DIMENSION DRAWINGS

The latest revision of the outline dimension drawing is presented in this section.

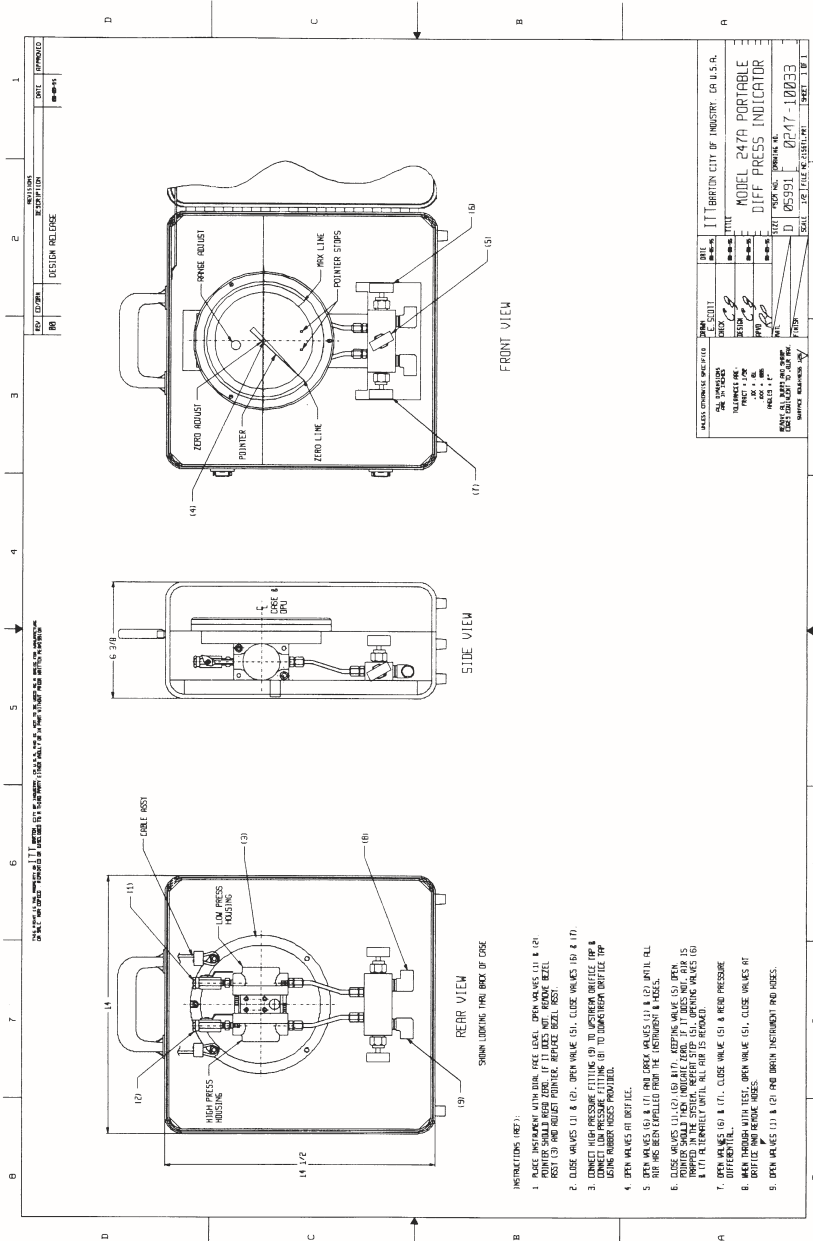

- INSTRUCTIONS (REF.):
1. PLACE INSTRUMENT WITH BURN FACE LEVEL. OPEN VALVES (1) & (2). POINTS SHOULD BEZE ZERO. IF IT DOES NOT, REMOVE BEZEL. (SEE INSTRUCTIONS FOR BEZEL ADJUSTMENT.)
 2. CLOSE VALVES (1) & (2). OPEN VALVE (5). CLOSE VALVES (6) & (17).
 3. POINTS OF PRESSURE (1) TO (4) SHOULD BE ZERO. POINTS OF PRESSURE (5) TO (17) SHOULD BE ZERO. TO CORRECT ZERO, SEE INSTRUCTIONS FOR ZERO ADJUSTMENT.
 4. OPEN VALVES (6) & (17). OPEN VALVES (1) & (2) UNTIL ALL AIR HAS BEEN EXPULSED FROM THE INSTRUMENT & PORES.
 5. CLOSE VALVES (1) & (2). KEEPING VALVE (5) OPEN, PRESSURE SHOULD BE ZERO. POINTS OF PRESSURE (1) TO (4) SHOULD BE ZERO. POINTS OF PRESSURE (5) TO (17) SHOULD BE ZERO. IF NOT, SEE INSTRUCTIONS FOR ZERO ADJUSTMENT.
 6. OPEN VALVES (6) & (17). CLOSE VALVE (5) & HIGH PRESSURE. MAKE THROUGH WITH TEST. OPEN VALVE (5). CLOSE VALVES (6) & (17) & LOW PRESSURE.
 7. OPEN VALVES (1) & (2) AND BURN INSTRUMENT AND PORES.
 8. OPEN VALVES (1) & (2) AND BURN INSTRUMENT AND PORES.

Product Warranty

A. Warranty

Cameron International Corporation ("Cameron") warrants that at the time of shipment, the products manufactured by Cameron and sold hereunder will be free from defects in material and workmanship, and will conform to the specifications furnished by or approved by Cameron.

B. Warranty Adjustment

- (1) If any defect within this warranty appears, Buyer shall notify Cameron immediately.
- (2) Cameron agrees to repair or furnish a replacement for, but not install, any product which within one (1) year from the date of shipment by Cameron shall, upon test and examination by Cameron, prove defective within the above warranty.
- (3) No product will be accepted for return or replacement without the written authorization of Cameron. Upon such authorization, and in accordance with instructions by Cameron, the product will be returned shipping charges prepaid by Buyer. Replacements made under this warranty will be shipped prepaid.

C. Exclusions from Warranty

- (1) THE FOREGOING WARRANTY IS IN LIEU OF AND EXCLUDES ALL OTHER EXPRESSED OR IMPLIED WARRANTIES OF MERCHANTABILITY, OR FITNESS FOR A PARTICULAR PURPOSE, OR OTHERWISE.
- (2) Components manufactured by any supplier other than Cameron shall bear only the warranty made by the manufacturer of that product, and Cameron assumes no responsibility for the performance or reliability of the unit as a whole.
- (3) "In no event shall Cameron be liable for indirect, incidental, or consequential damages nor shall the liability of Cameron arising in connection with any products sold hereunder (whether such liability arises from a claim based on contract, warranty, tort, or otherwise) exceed the actual amount paid by Buyer to Cameron for the products delivered hereunder."
- (4) The warranty does not extend to any product manufactured by Cameron which has been subjected to misuse, neglect, accident, improper installation or to use in violation of instructions furnished by Cameron.
- (5) The warranty does not extend to or apply to any unit which has been repaired or altered at any place other than at Cameron's factory or service locations by persons not expressly approved by Cameron.

Product Brand

Barton® is a registered trademark of Cameron International Corporation ("Cameron").

MEASUREMENT SYSTEMS

Formerly: NuFlo Measurement Systems • Barton Instrument Systems • Caldon, Inc.

HOUSTON
HEAD OFFICE | **281.582.9500**

NORTH
AMERICA | **1.800.654.3760**
ms-us@c-a-m.com

ASIA
PACIFIC | **603.2287.1039**
ms-asiapacific@c-a-m.com

EUROPE,
MIDDLE EAST
& AFRICA | **44.1243.826741**
ms-uk@c-a-m.com

USA • CANADA • UK • SCOTLAND • CHINA • UAE
ALGERIA • MALAYSIA • SINGAPORE • www.c-a-m.com/flo

